

MAHLE

Industrial Filtration

Vertical pressure leaf filter

Versis

1. Introduction

The Versis pressure leaf filter is a vertical pressure filter from MAHLE Industrial Filtration with a large specific filtration area due to the shape of the filter elements. We have been building these filters for more than 60 years.

The Versis range incorporates several product improvements making the design state of the art. More than 10000 vertical and horizontal pressure leaf filters have been sold worldwide for various applications so far.

The double sided filter leaves are made from stainless steel. The rigid filter leaves have five layers of stainless steel wire screen. The top layer of screen depends on the application. The filter leaves are individually mounted on the central manifold, which allows the removal of any or all of the filter leaves easily and quickly.

The filter cake can be dried with compressed air, inert gas or steam. The cake is discharged by a pneumatic vibrator, through a large butterfly valve.



2. Pressure leaf system advantages

The Versis pressure leaf filter is an enclosed filtration system and can be fully automated. This filter produces a high filtrate clarity after the clarification run and is also suitable for all kinds of filter aids. The regeneration time between the filtration cycles is short. The vertical filters require only a small footprint and are standard equipped with a cover lift assembly. The design of the pressure leaf filter keeps maintenance to a minimum.

These advantages result in an economical filtration solution.

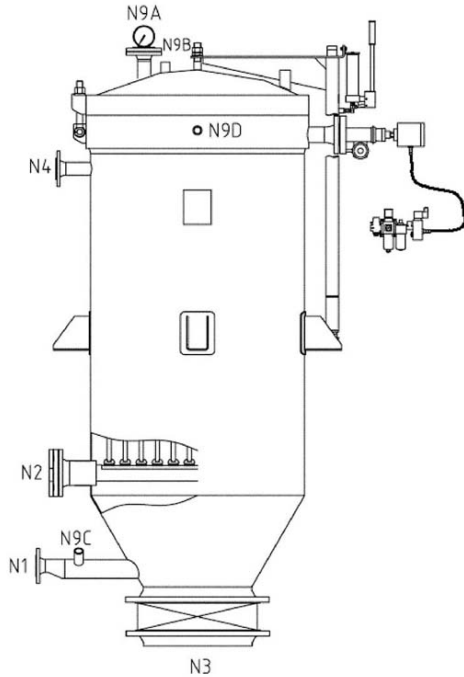

3. Standard design data

Material tank	: carbon steel (stainless steel optional)
Material filter elements	: stainless steel
Design pressure	: -1/6 bar(g)
Design temperature	: 0/150 °C
Max. allowable pressure drop	: 4.5 bar
Design	: ASME VII div. 1 (Versis 460/610/760: AD-2000)
Approval	: PED 97/23/EC optional: SELO 02257 (China) GOST R (Russia)

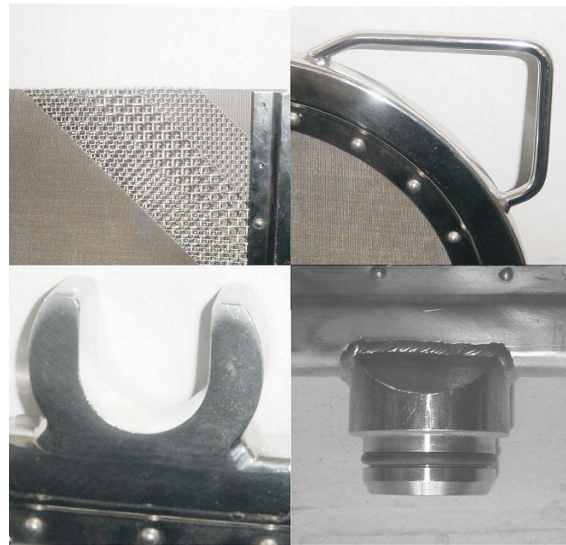

Versis model	460	610	760	800	1000	1200 (1500)	1200 (1810)	1400 (1500)	1400 (1810)	1600	1800	2000
Tank diameter [mm]	460	610	760	800	1000	1200	1200	1400	1400	1600	1800	2000
Element height [mm]	780	930	1500	1500	1500	1500	1810	1500	1810	1810	1810	1810
N1 Feed / Drain DN	40	40	50	80	80	80	80	80	80	80	100	100
N2 Filtrate outlet DN	50	50	50	80	80	80	80	80	100	100	100	125
N3 Cake discharge DN	250	300	350	350	500	500	500	600	600	600	600	600
N4 Vent DN	25	25	25	50	50	50	50	80	80	80	80	100

4. Specifications

Versis model	Filter Area [m ²]	Cake volume [dm ³]	Filter leaves	Filter volume [dm ³]	Leaf spacing [mm]	Floor space [mm x mm]	Height [mm] (incl. lifting height for elements)	Weight (empty) [kg]
460-2/780	2	40	5	210	70	1420 x 1150	2320	440
610-5/930	5	120	7	430	70	1540 x 1210	2820	520
760-8/930	8	170	9	760	70	1710 x 1890	2860	610
800-12/1500	12	270	7	1050	75	1945 x 1830	3980	810
800-14/1500	14	310	9					
1000-19/1500	19	410	8	1690	75	2360 x 1600	4085	1190
1000-22/1500	22	490	10					
1000-24/1500	24	530	12					
1200-27/1500	27	590	10	2520	75	2720 x 1790	4255	1525
1200-31/1500	31	680	12					
1200-34/1500	34	750	14					
1200-37/1810	37	810	12	2855	75	2720 x 1790	4855	1645
1200-40/1810	40	880	14					
1400-45/1500	45	990	15	3540	75	3100 x 2080	4380	2125
1400-48/1500	48	1050	17					
1400-54/1810	54	1180	15	3990	75	3100 x 2080	4990	2275
1400-57/1810	57	1250	17					
1600-61/1810	61	1330	14	5440	75	3100 x 2080	5195	2825
1600-67/1810	67	1470	16					
1600-72/1810	72	1590	18					
1800-80/1810	80	1750	16	7115	75	4300 x 2710	5365	3525
1800-86/1810	86	1900	18					
1800-92/1810	92	2030	20					
1800-95/1810	95	2100	21					
2000-99/1810	99	2180	18	9475	75	4500 x 2350	5570	4900
2000-107/1810	107	2350	20					
2000-113/1810	113	2490	22					
2000-118/1810	118	2580	24					
Other models upon request								

Notes: *Dimensions are for reference only.
Subject to technical alteration without prior notice.*

MAHLE

Industrial Filtration

MAHLE Industrial Filtration (Benelux) B.V.

P.O.Box 396 1800 AJ

Alkmaar - The Netherlands

Phone +31 (0) 72 5273400

Fax +31 (0) 72 5125207

mahle.amafilter@mahle.com

www.mahle-industrialfiltration.com

10/2009